



intimus DIS 600/1000

FOR THE HIGHEST SAFETY REQUIREMENTS



RELIABLE DESTRUCTION OF YOUR DATA

The security requirements for destruction of sensitive data are increasing worldwide. The higher the security requirements, the smaller the data media which must be destroyed.

Disintegrators are therefore used where standard shredding technology reaches its limits. They can be used to shred a wide variety of materials into tiny particles or granules.

The technology of the disintegrators meets even the highest security requirements of industrial users, government agencies and banknote printers, while at the same time ensuring high throughput. Quick-change screens offer the best possible flexibility. This makes it possible to security level from P-3 to P-7 can be adjusted immediately.

Our long-term partners include central banks, security printers, intelligence agencies, the military and other government agencies from around the world, as well as industrial and waste management customers.

The **intimus DIS 600/1000** is perfectly suited for the reliable and economical shredding of paper and plastics such as:

- **Paper documents and valuable printed matter** such as documents, banknotes, passports or ID cards
- **Magnetic data carriers** such as smart cards or floppy disks
- **Optical data carriers** such as CDs or DVDs





DISINTEGRATORS - A PROVEN TECHNOLOGY

Disintegrators have a rotor made from solid material with screwed-on and easily regrindable blades made from high-quality tool steel. The material is fed into the shredding chamber from above through a hopper and cut there, as in a pair of scissors, between the very fast rotating rotor blades (sitting on the rotor) and the fixed stator blades (mounted in the housing). As the blades cut the material into undefined shapes and sizes, a screen is required underneath the rotor. This screen ensures that only particles of a certain size leave the machine.

The particles remain in the cutting chamber until they are small enough to fit through the holes in the screen. By fitting a screen with a larger or smaller hole diameter, the cutting size produced can be changed in a matter of minutes and the security level adjusted from P-3 up to P-7. A dust extractor is required to convey the particles through the screen into a collection bag, press container or briquetting press. Disintegrators from intimus are characterised by low vibration at high revolutions, uniform load and low energy consumption.

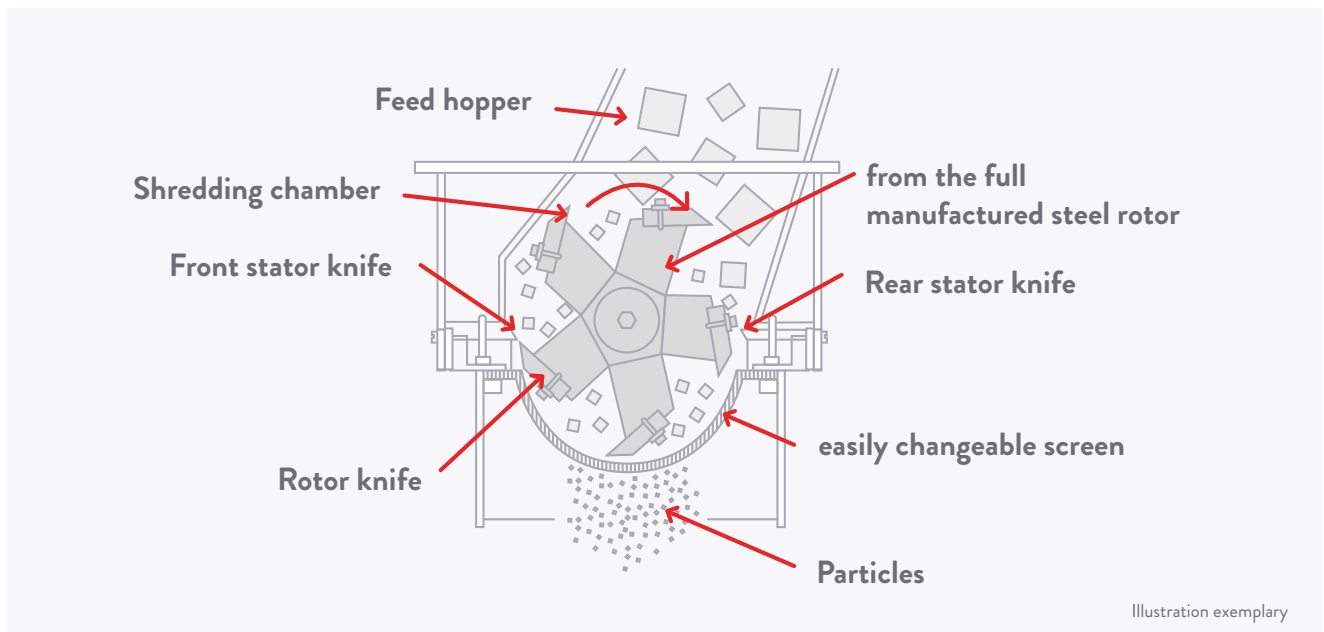

Knife made of high quality, hardened tool steel
(Illustration exemplary)



Interchangeable screens to achieve different security levels.



Exemplary shown
intimus DIS 260/410

Technical Design

USPs

- The cutting sizes and the achievable security levels of a disintegrator depend on the perforation of the screen used. With our intimus disintegrators, you can perform a screen change within a few minutes and adapt the machine specifically to your safety requirements.
- Screens are available for security levels P-3 to P-7 according to DIN 66399. Even the strictest NSA standards of the US government are met.
- For maximum throughput and best durability, the screens are made of thick, drilled (not punched) steel plate with optimised hole spacing and geometries.
- Thanks to the generous working width, all common paper and EDP formats can be easily fed, depending on the model.
- A clear panel with safety concept and protection device facilitates operation.
- The rotors are made of solid steel on high-precision CNC machining centers. They are perfectly balanced, run almost vibration-free even at high speeds and are characterized by low energy consumption.
- The durable knives are made of high quality hardened tool steel. Worn or damaged knives can be easily replaced or resharpened many times by any specialist dealer.
- The upper part of the housing can be folded back in just a few steps. The wide-opening chassis allows best accessibility to the screen as well as to all rotor and stator knives for convenient and quick replacement.
- Suitable soundproof booths, dust extractors or briquetting presses are available for all disintegrators.
- For larger models from intimus DIS 300/450 upwards there are optional feeder belts, pre-shredders and magnetic and magnetic separators.

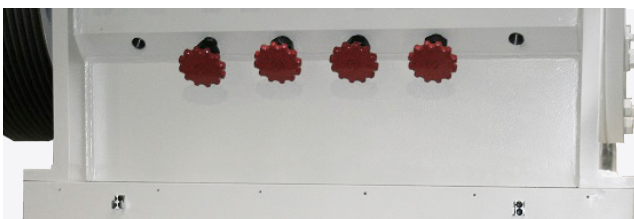

Uncomplicated screen change (Illustration exemplary)



Easy service access (Illustration exemplary)

intimus Disintegrators

PRODUCT INFORMATION

intimus has a wide range of models for different performance requirements and applications. This includes 6 disintegrators, from the intimus DIS 150/230 for shredding paper and CDs in the office to the intimus DIS 600/1000 for centralized

shredding in large administrative buildings, military facilities or manufacturing plants. In this way, applications from security level P-3 to P-7 according to DIN 66399 and according to NSA-CSS 02-02 with throughput rates from 40 to 2 000 kg/h can be covered.



intimus DIS 150/230



intimus DIS 200/410



intimus DIS 260/410



intimus DIS 300/450



intimus DIS 300/600



intimus DIS 600/1000



40 – 2 000 kg/h *



230 – 1 000 mm



approx. 100 dB(A)



400 V / 50 Hz **

Origin country  Germany

Shredding material Paper documents (with staples and paper clips), Banknotes, passports, ID cards, smart cards, floppy disks, CDs and DVDs

- * Theoretical throughput capacity: All data refer to paper. The output may vary depending on the screen used, the type of feeder and the paper quality. All data supplied without guarantee. Subject to technical and optical changes.
- ** Other voltage variants are available on request.
- *** Sizes are not to scale.



ANY QUESTIONS?
GET IN CONTACT:

sales.de@intimus.com
T. +49 (0)7544 60-0
www.intimus.com



intimus Disintegrators

PRODUCT OVERVIEW



	intimus DIS 150/230	intimus DIS 200/410	intimus DIS 260/410	intimus DIS 300/450	intimus DIS 300/600	intimus DIS 600/1000
Paper throughput P-3 acc. to DIN 66399	up to 40 kg/h*	up to 200 kg/h*	up to 320 kg/h*	up to 530 kg/h*	up to 700 kg/h*	up to 2 000 kg/h*
Paper throughput P-4 acc. to DIN 66399	up to 27 kg/h*	up to 180 kg/h*	up to 290 kg/h*	up to 450 kg/h*	up to 600 kg/h*	up to 1 700 kg/h*
Paper throughput P-5 acc. to DIN 66399	up to 18 kg/h*	up to 160 kg/h*	up to 270 kg/h*	up to 370 kg/h*	up to 490 kg/h*	up to 1 400 kg/h*
Paper throughput P-6 acc. to DIN 66399	up to 15 kg/h*	up to 125 kg/h*	up to 200 kg/h*	up to 250 kg/h*	up to 330 kg/h*	up to 1 200 kg/h*
Paper throughput P-7 acc. to DIN 66399	up to 13 kg/h*	up to 100 kg/h*	up to 150 kg/h*	up to 190 kg/h*	up to 250 kg/h*	up to 930 kg/h*
Working width	230 mm	410 mm	410 mm	450 mm	600 mm	1 000 mm
Rotor diameter	150 mm	200 mm	260 mm	300 mm	300 mm	600 mm
Knife quantity	Rotor 3 / Stator 2	Rotor 5 / Stator 2	Rotor 5 / Stator 2	Rotor 5 / Stator 2	Rotor 5 / Stator 2	Rotor 7 / Stator 2
Knife design	Single Diagonal Cut	Single Diagonal Cut	Single Diagonal Cut	Dual Diagonal Cut	Dual Diagonal Cut	Dual Diagonal Cut
Processable Paper size	DIN A4	DIN A3	DIN A3	DIN A2	DIN A1	DIN A0
Motor power	4 kW	7,5 kW	11 kW	18 / 30 kW	22 / 30 kW	75 / 110 kW
Noise level	≈ 100 dB(A)	≈ 100 dB(A)	≈ 100 dB(A)	≈ 100 dB(A)	≈ 100 dB(A)	≈ 100 dB(A)
Net weight	ca. 230 kg	ca. 615 kg	ca. 770 kg	ca. 2 400 kg	ca. 2 600 kg	ca. 7 200 kg
Width / Depth / Height	540 / 860 / 1 230 mm	880 / 1 150 / 1 580 mm	880 / 1 150 / 1 580 mm	1 240 / 1 600 / 2 390 mm	1 390 / 1 600 / 2 390 mm	1 760 / 2 470 / 3 540 mm
Attachment piece dust extractor Ø	50 mm	100 mm	100 mm	120 mm	2x120 mm	2x160 mm

* Theoretical throughput: All data refer to paper. The output may vary depending on the screen used, the type of feed, and the paper quality. All data supplied without guarantee. Subject to technical and optical changes.

** Size ratios are not to scale.



intimus Disintegrators

SAFETY LEVELS OF THE SCREENS ACC. DIN 66399 (ISO/IEC 21964)



intimus DIS 600/1000*

Screen	P	F	O	T	H	E
20 mm	3	-	3	3	-	2
12 mm	4	1	4	4	-	3
9 mm	5	2	5	5	-	4
5 mm	7	3	6	6	-	5



intimus DIS 150/230*

Screen	P	F	O	T	H	E
20 mm	3	-	2	3	-	2
9 mm	4	1	3	4	-	3
5 mm	5	2	4	5	-	4
4 mm	6	3	5	6	-	5
3 mm	7	4	6	7	-	5
2,15 mm	7	4	6	7	-	5



intimus DIS 200/410*

Screen	P	F	O	T	H	E
20 mm	3	-	2	3	-	2
12 mm	4	1	3	4	-	3
9 mm	5	2	4	5	-	4
5 mm	6	3	5	6	-	5
3 mm	7	4	6	7	-	5
2,15 mm	7	4	6	7	-	5



intimus DIS 260/410*

Screen	P	F	O	T	H	E
20 mm	3	-	2	3	-	2
12 mm	4	1	3	4	-	3
9 mm	5	2	4	5	-	4
5 mm	6	3	5	6	-	5
3 mm	7	4	6	7	-	5
2,15 mm	7	4	6	7	-	5



intimus DIS 300/450*

Screen	P	F	O	T	H	E
20 mm	3	-	3	3	-	2
12 mm	4	1	4	4	-	3
9 mm	5	2	5	5	-	4
5 mm	6	3	5	6	-	5
3,5 mm	7	3	6	6	-	5



intimus DIS 300/600*

Screen	P	F	O	T	H	E
20 mm	3	-	3	3	-	2
12 mm	4	1	4	4	-	3
9 mm	5	2	5	5	-	4
5 mm	6	3	5	6	-	5
3,5 mm	7	3	6	6	-	5

* Other screens available. ** Size ratios are not to scale.



Installation instructions*

intimus DIS 600/1000

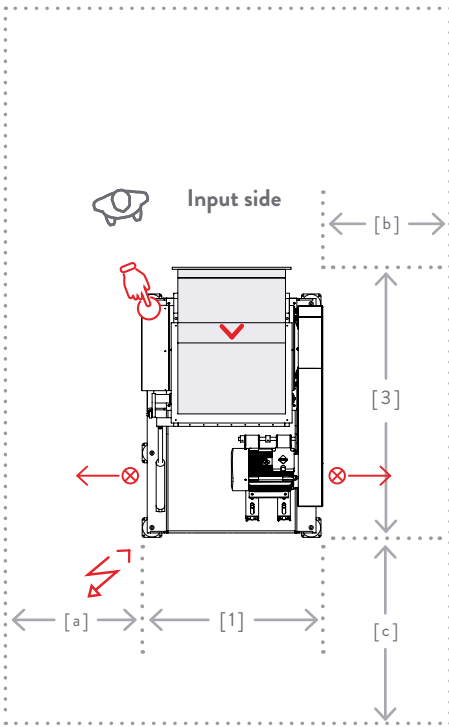

- Electrical access 3 phases**
- Position of the controls**
- Dust extractor connection on both sides, right and left - The dust extractor is customised to the customer's requirements**

Shipping	Electrical access 3 phases
----------	----------------------------

- Packaging information on request
- 400 V / 50 Hz Direct connection in the control cabinet 160 Amp. (EU)
- Other voltage variants are available on request.

Dimensions	cm	cm	
[1] Width	176	[5] Depth with extraction funnel pulled out	444
[2] Width insertion chute	100	[6] Height	354
[3] Depth	247	[7] Height insertion shaft	81,5
[4] Depth with open Housing	330	[8] Height insertion	267

Open spaces / distances	cm	cm	
[a] min.	100	[b] min.	100
[c] min.	80		

Required fuse protection on site

- Circuit breaker with tripping characteristic C
- or fuse gL/gG Allocation type 1 according to IEC/EN 60947-4-1
- 400 V / 50 Hz = 160 Amp.

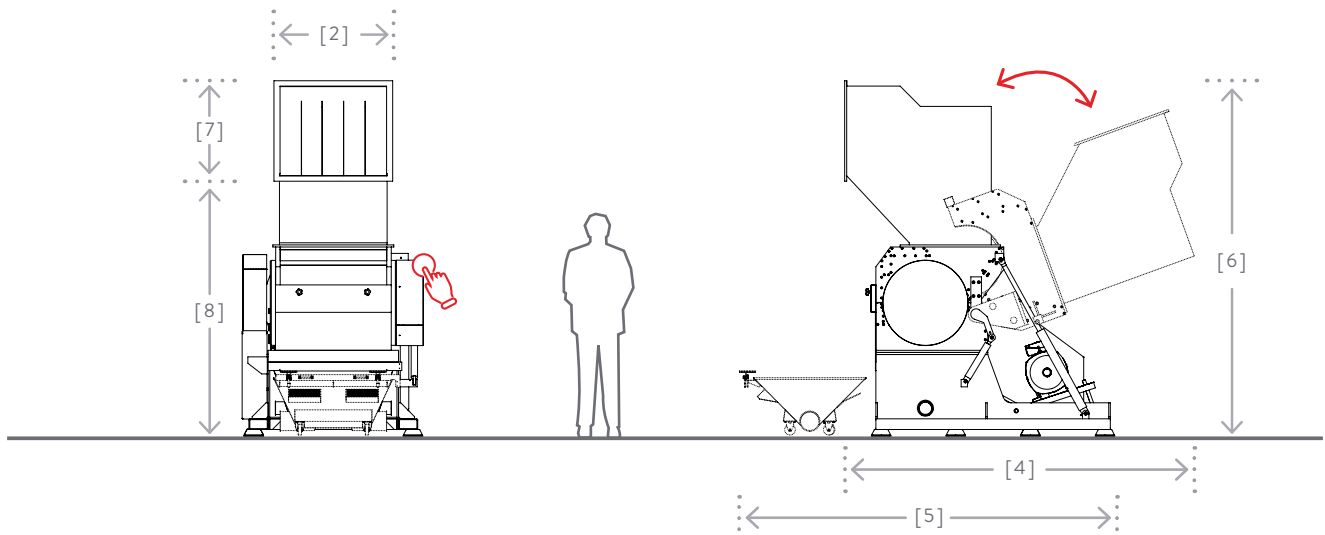

* All data supplied without guarantee. Subject to technical and optical changes.